

G-Lok[®] CLAMP CONNECTORS

The Ultimate Sealing Solution
for Demanding Environments

affgroup.net.au





GLOBAL PLAYER. LOCAL MANAGEMENT.

G-Lok® Clamp Connectors are high-integrity sealing systems widely used in the oil and gas industry. They serve as an efficient alternative to traditional flanged connections, suitable for various applications including onshore, offshore, subsea, FPSO, and FLNG facilities.

The connectors are specifically designed for systems requiring high-integrity seals, close piping and hookup arrangements, low-weight piping, and connections that require quick disassembly. They are particularly effective in rapid cycling operating conditions over extended periods and severe environments where routine maintenance is impractical.

The G-Lok® connectors offer several configurations, such as standard 2-piece, slimline, 3-piece, and subsea connectors, with sizes ranging from NPS 1/2 to NPS 36 and pressure ratings up to 2,000 bar (30,000 psi).

OIL & GAS

Onshore and Offshore: Used for high-pressure and high-temperature piping systems in both onshore and offshore environments.

Subsea: Ideal for subsea pipelines and equipment due to their reliability and resistance to harsh underwater conditions.

FPSO and FLNG: Utilised in FPSO units and FLNG facilities for various critical connections.

CHEMICAL

Process Piping: Ensures leak-proof connections in chemical processing plants, handling various aggressive chemicals and fluids.

Reactor and Vessel Connections: Provides secure connections for reactors and pressure vessels operating under extreme conditions.

POWER GENERATION

Steam and Gas Turbines: Used in high-pressure steam and gas turbine applications, where reliable connections are crucial for efficiency and safety.

Nuclear Power Plants: Suitable for nuclear power applications, ensuring high-integrity connections in critical systems.



BENEFITS OF USING G-LoK® CONNECTORS:

Safety: Reduces the risk of leaks and failures, enhancing the safety of piping systems.

Efficiency: Decreases installation and maintenance time, improving overall operational efficiency.

Cost-Effectiveness: Although the initial cost may be higher than traditional flanges, the long-term savings in maintenance and downtime make G-Lok® connectors a cost-effective solution.

G-Lok® connectors offer a robust and reliable solution for high-pressure and high-temperature applications across various industries. Their ability to provide a secure, leak-proof connection while being easy to install and maintain makes them a preferred choice for many critical piping systems.

KEY FEATURES OF G-LoK® CONNECTORS

High-Pressure and High-Temperature Capability:

Designed to handle pressures up to 30,000 psi and temperatures up to 1,500°F, making them suitable for the most demanding applications.

Metal-to-Metal Seal: Provides a reliable and leak-proof seal through a metal-to-metal connection, which is more durable than traditional gaskets and seals.

Ease of Installation and Maintenance: The clamp and hub design allows for quick and easy assembly and disassembly, reducing installation time and maintenance costs.

Compact and Lightweight: More compact and lightweight compared to traditional flanged connections, which helps in reducing the overall weight and space requirements of piping systems.

Versatility: Available in a range of sizes and materials to meet the specific needs of different applications, including carbon steel, stainless steel, and various alloys.

DESIGN

- Standard G-Lok® Clamp Connectors
- Hinge Closure Clamp Connectors
- Slimline Clamp Connectors
- Subsea Clamp Connectors

SIZE

- NPS 1/2 to NPS 36
- DN 15 to DN 900

PRESSURE RATING

- Design Pressure up to 2,000 bar
- Design Pressure up to 30,000 psi

The G-Lok® Clamp Connectors are meticulously manufactured and engineered to meet specific needs. The combination of clamp, seal ring and hub dimensions is based on the unique requirements and piping conditions. This ensures that our connectors deliver superior performance and reliability in every application.

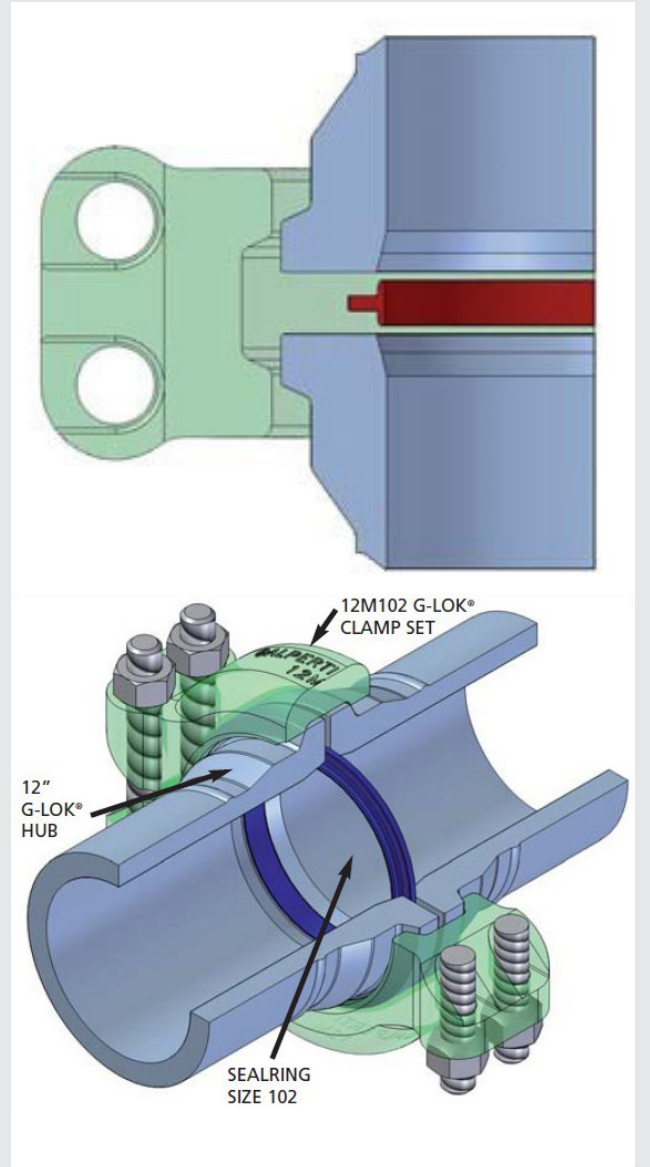

KEY ADVANTAGES FOR:

- Systems requiring high-integrity seals
- Systems that require close piping and hookup arrangements
- Systems that require low weight piping and connections
- Systems that require connections quick disassembly
- Rapid cycling operating conditions over extended periods of time
- Severe conditions with no routine maintenance requirements
- Hydrogen Services.

TECHNICAL FEATURES

- Easy assembly/disassembly
- High-pressure design combined with strong load capacity
- Design suitable for cryogenic and high temperature services
- Compact design and low weight
- Re-usable, pressure energised, metal to metal sealing technology
- Full flexibility
- Design in fully compliance to specified standards (ASME VIII Div.1 and 2, ASME B31.3, API 6A) or any Project specific need
- Fire-safe tested and certified in accordance with API 6FB
- Lloyd's register and DNV approved design.

OUR STRENGTHS

Specialised Forged Products: We specialise in customised forged products for demanding applications.

In-House Manufacturing: All manufacturing processes, including forging, heat treatment, machining, and painting, are conducted in-house, ensuring optimal control at every stage

Specification Compliance: We conduct thorough specification reviews to ensure complete compliance with all requirements.

Quality and Traceability: Our commitment to high quality and superior customer service includes full traceability of materials back to the raw source.

Ongoing Support: We provide ongoing solutions, advice, and recommendations throughout the entire lifespan of your plant.

Global Sourcing: We source superior quality products from globally renowned manufacturers, all of whom are ISO 9001 certified.

Material Selection: Our meticulous material selection process ensures extended facility longevity.

Consistent Delivery: Renowned for our consistent delivery of high-quality products

Prompt Responses: Rely on us for prompt and precise responses to your inquiries.

Comprehensive Project Management: Our services cover order management, technical queries, documentation, expediting, logistics, and more.

Expert Guidance: Receive expert guidance to ensure accurate installation, maintenance, and sustained functionality.

“Bringing the manufacturer to the client” is the principle that drives our success. AFF offers a comprehensive, globally competitive supply chain, delivering innovative and cost-effective solutions tailored to client specifications. Our goal is to be the preferred supply partner, consistently ensuring that our product quality exceeds client expectations.



Australasian Fittings & Flanges Pty Ltd

ABN 84 118 519 332

8 Wittenberg Drive, Canning Vale 6155 WA

+61 8 6323 8090 | sales@affgroup.net.au

affgroup.net.au

